



UNIVERSAL

ENVIRONMENTAL CONTAINMENT SOLUTIONS

LINERS™

©

*Introducing
the next
generation in
environmental
protection.*

*The ultimate
containment
liners for the
precast and
retrofit
industries.*

Patents Pending

Features of the Miller Environmental Universal Liner System™

- Designed for any new, 1 or 2 piece precast cement products by insertion or using our exclusive precasting method.
- Made to fit the inner core of your mold before pouring concrete.
- Custom made to fit precasted cement products of any size, shape, or configuration, new or existing.
- Requires no costly excavation!
- Fastens to the interior of the tank and fits easily through the access cover.
- Ziplock, easy-connection system available for 1 piece, 2 piece or more precasted cement products.
- Installs easily and quickly.
- Durable quality adds years to the life of all precasted cement products.
- Models range from our Cast in Place to our Retro-Fit versions.
- Our patent pending polymer material can be formulated to be chemically resistant to virtually any liquid.
- Helps meet vacuum-testing, state, and federal agency codes.
- Protects groundwater from contamination.

Groundwater is the major source of our nation's drinking water. With Americans consuming approximately 110 million gallons of water a day, it has become increasingly important to protect our limited groundwater resources. Contrary to popular belief, preserving our groundwater does not have to be a difficult or costly venture.

The **Miller Environmental Universal Liner System™** is an effective and inexpensive solution to precasted cement product leakage. Our **Universal Liner™** is guaranteed to make your product both watertight and environmentally safe. Our patent pending polymer material has been developed and specially formulated to be flexible and chemically resistant. It has been tested and proven to provide a long-lasting barrier to such liquids as raw sewage, and other wastes.

The **Universal Liner™** can be utilized for any or all of the following products:

- Septic tanks
- Holding tanks
- Clarifiers
- D-boxes
- Utility vaults
- Burial vaults
- Pipes
- Breakout barriers
- Most precasted cement products

Miller Environmental Products has a patent pending method for attaching the **Universal Liner™** to the interior of your precasted cement product as part of the manufacturing process. This method not only creates a watertight seal but also prevents deterioration of your product's concrete material. A ziplock, easy-connection system is also available to completely enclose or connect any 1 piece, 2 piece or more precasted cement product.

Cast In Place System

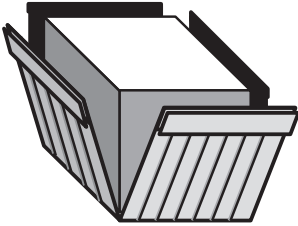

Empty mold with core

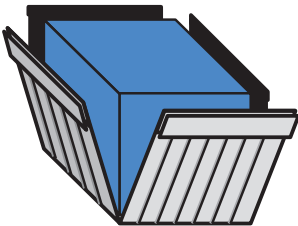

The **Universal Liner™** is placed over the core of the mold.

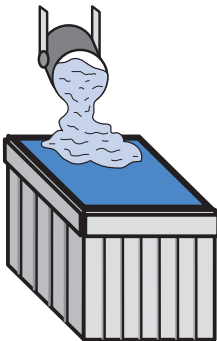

The mold is closed and cement is poured as normal directly on the **Universal Liner™**.

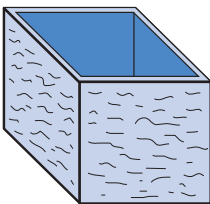

Finished vault is now completely lined on the inside with the **Universal Liner™**.

Patents Pending

Retro-Fit System

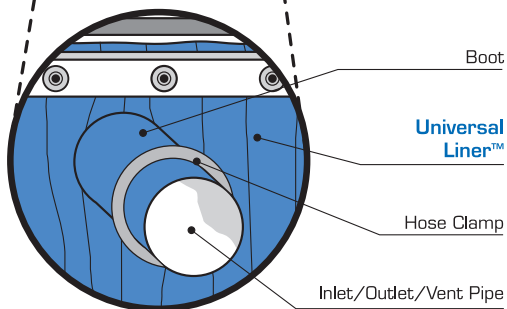
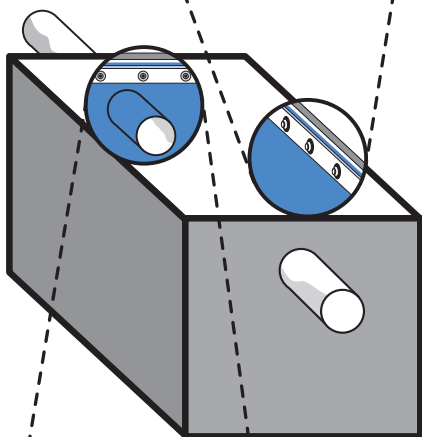
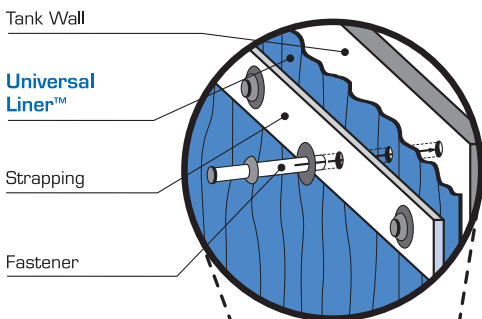

Patents Pending

The **Universal Liner™** can be electromagnetically welded to form any size, shape or configuration required by your precasted cement product. Our patent pending polymer material is available in various thicknesses and can be formulated to be chemically resistant to virtually any liquid contained by your product.

Our **Universal Liner™** can be used for new and existing precasted cement products. We manufacture a patent pending liner for the purpose of retrofitting products already in use. This liner can be installed through the access cover without costly excavation of the existing product.

Our **Universal Liner™** will help you to meet new testing codes and requirements. Our product will also enable you to fulfill the constantly changing demands of both your customers and state and federal agencies. In all areas in which we have demonstrated our **Universal Liner™**, we have received great acceptance and support from the Department of Environmental Protection (DEP), Board of Health agents, and water pollution agencies.

Join the effort to clean up our environment!
The **Miller Environmental Universal Liner System™** is the next generation in environmental protection for your precasted cement products.

**New Products • New Sales
New Profits**

*For more information on our products,
or to find out how to become a
sales representative or distributor
in the U.S. or abroad, please
contact us at 508-697-3710*



MILLER ENVIRONMENTAL

PRODUCTS, INC.

*508-697-3710
Fax 508-697-0606*

*The Universal Liner™ logo,
Miller Environmental Products logo,
all artwork and references contained herein,
© 1998-99 Miller Environmental Products, Inc.*